

Numark

MIXSTREAM PRO
MIXSTREAM PRO+
MIXSTREAM PRO GO

User Guide

English
v3.0.0

Table of Contents

Introduction.....5

 Box Contents..... 5

 Support..... 5

 Product Registration 5

 Devices & File Analysis 6

 Configuration 6

Features.....7

 Top Panel..... 7

 Front Panel 10

 Rear Panel 10

Operation 11

 Touchscreen Overview 11

 Performance View..... 11

 Track Overview & Waveform..... 11

 Central Library Preview 12

 Toolbar..... 12

 Library View 13

- Performing.....15**
 - Loading Tracks..... 15
 - Searching & Filtering Tracks..... 16
 - Editing Playlists..... 17
 - Playlist Deck..... 18
 - Playback & Cueing 19
 - Syncing & Pitch Adjustment 19
 - Beat Grid Editing20
 - Pad Modes..... 21
 - Cue Mode.....21
 - Saved Loop Mode.....21
 - Auto Loop Mode.....21
 - Roll Mode21
 - Sampler Mode.....22
- Control Center 23**
 - Parameters23
 - User Profile.....24
 - Settings.....26
 - Source.....28
 - Engine Remote Library 29
 - Wi-Fi.....29
 - Record30
 - Engine Lighting..... 31
 - Preferences 32

Appendix 33

FX Parameters 33

Technical Specifications 34

Trademarks & Licenses 36

Introduction

Thank you for purchasing your Mixstream Pro hardware. At Numark, we know how serious music is to you. That's why we design our equipment with only one thing in mind—to make your performance the best it can be. We're honored and excited to play a part in your musical & creative DJ journey!

Note: This User Guide covers the features and functions Mixstream Pro, Mixstream Pro +, and Mixstream Pro Go. All product references to Mixstream Pro also apply to Mixstream Pro + and Mixstream Pro Go unless otherwise noted.

Box Contents

Mixstream Pro or Mixstream Pro + or Mixstream Pro Go

Power Supply

USB Cable

Engine DJ Software Download Card

Display Cleaning Cloth

Quickstart Guide

Safety & Warranty Manual

Important: Visit enginedj.com/downloads to download the Engine DJ software.

Support

For the latest information about this product (documentation, technical specifications, system requirements, compatibility information, etc.) and product registration, visit numark.com.

For additional product support, visit numark.com/support.

Product Registration

Your product may include exclusive software and/or promotions which can only be accessed by registering your new product on the Numark website.

To check eligibility and access the available content, please register your product by following the instructions below.

1. Visit numark.com.
2. Click “My Account” to access your existing account or to create a new account.
3. Once signed in, click “Register A Product”.
4. Complete the form and click “Submit Registration”.
5. Upon successful registration, any applicable software downloads, exclusive content, and promotional offers will be shown in your account.

Devices & File Analysis

Mixstream Pro can play music files from USB drives, SD cards, or connected streaming and cloud services. Make sure you are using only the supported file systems (for USB drives or SD cards) and file formats (for music files) listed below.

Supported file systems: exFAT (recommended), FAT32

Supported file formats: AAC/M4A	MP3 (32–320 kbps)
AIF/AIFF (44.1–192 kHz, 16–32-bit)	MP4
ALAC	Ogg Vorbis
FLAC	WAV (44.1–192 kHz, 16–32-bit)

Although Mixstream Pro can play tracks that have not been analyzed yet, pre-analyzing them allows its features to work most effectively. You can analyze tracks in one of two ways:

- **On your Mixstream Pro hardware, load the track:** When you load a track to play, your Mixstream Pro hardware will automatically analyze it (if it has not already been analyzed). This may take a moment to complete, depending on the length of the track. You can start playing the track from the beginning **immediately**, though you will need to wait a moment for the analysis to finish.
- **Use Engine DJ software:** The included Engine DJ software can pre-analyze your music library to use with your Mixstream Pro hardware. You can also use it to organize your library and manage your hardware preferences (see [Operation](#) to learn more about this).

Visit enginedj.com/downloads to download the Engine DJ software.

To eject a USB drive or SD card:

1. Press **Source**. A list of connected devices will appear in the touchscreen.
2. Tap the eject icon for the device you would like to eject. If a track on the device is currently playing, you will be asked if you want to continue ejecting, which will stop the track. Tap **Cancel** to cancel ejecting the device, or tap **Eject Anyway** to eject it.

To eject additional devices, repeat Step 3.

To return to the previous screen, press **Source** again, or tap the **X** in the upper-right corner.

Configuration

Mixstream Pro hardware has several settings that you can customize in the [User Profile](#) and [Settings](#) menus. See [Control Center](#) to learn about these settings.

Features

Note: All product references to Mixstream Pro also apply to Mixstream Pro + and Mixstream Pro Go unless otherwise noted.

Top Panel

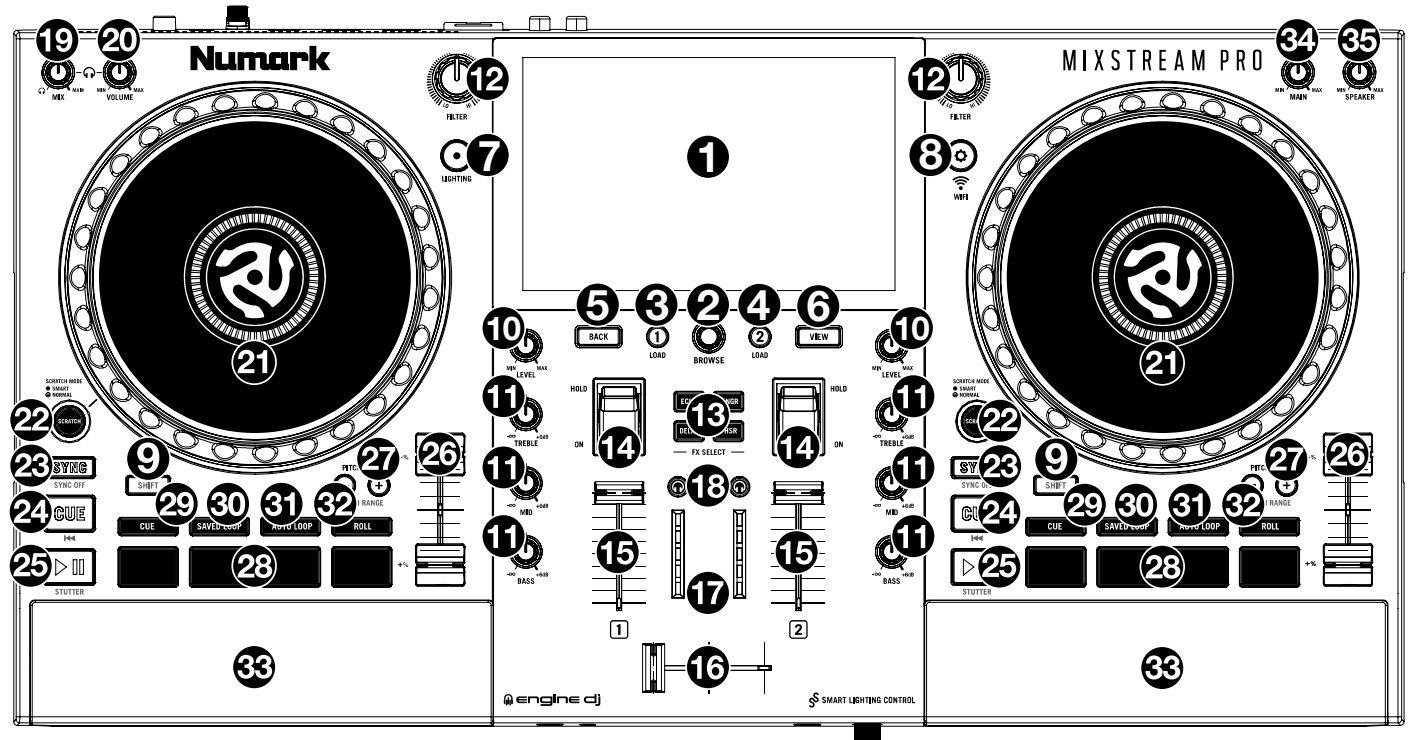

1. **Touchscreen:** This full-color, multi-touch display shows information relevant to Mixstream Pro's current operation. Touch the touchscreen (and use the hardware controls) to control the Mixstream Pro interface.
2. **Browse Knob:** Turn this knob to navigate through lists. Press the knob to move forward in the touchscreen or select a song to load on either deck.
Press and hold **Shift** and press this knob to load the selected track to the Prepare list.
3. **Load 1:** Press this button to load the selected track to Deck 1.
Quickly double-press this button to instant double the track currently playing on Deck 2 to Deck 1.
4. **Load 2:** Press this button to load the selected track to Deck 2.
Quickly double-press this button to instant double the track currently playing on Deck 1 to Deck 2.
5. **Back:** Press this button to move back in the touchscreen.
6. **View:** Press this button to cycle between the **Library View** and **Performance View**.
Hold **Shift** and press the **View** button to switch between horizontal and vertical waveform views in Performance View.
7. **Lighting:** Press this button to open the **Engine Lighting** menu.
8. **Control Center:** Press this button to open the **Control Center** menu, where you can quickly adjust commonly used settings and navigate to the User Profile, Settings, Source, Wi-Fi, Record, and Engine Lighting menus.
9. **Shift:** Press and hold this button to access secondary functions of other controls.
10. **Channel Level:** Turn this knob to adjust the level of the pre-fader, pre-EQ audio signal for the channel.
11. **Channel EQ:** Turn these knobs to boost or cut the high, mid-range, and low frequencies for the channel.
12. **Filter:** Turn this knob to apply a filter to the channel. Starting from the center (12:00) position, turn it counter-clockwise to apply a low-pass filter, or turn it clockwise to apply a high-pass filter.

- 13. **FX Select:** Press these buttons to enable or disable the selected effect: Echo, Delay, Flanger or Phaser.
- 14. **Effects Toggle:** Move this toggle switch away from you to activate the selected effect—the toggle will latch to that position. Pull the toggle back to the center position to deactivate the effects.

Pull and hold this toggle toward you to activate the selected effect momentarily, and release the toggle to deactivate the effect—the toggle will return to the center position.
- 15. **Channel Fader:** Use this fader to adjust the channel’s volume level.
- 16. **Crossfader:** Use the crossfader to mix between Deck 1 and Deck 2.
- 17. **Main Level Meters:** These LEDs display the audio signal level of the main mix (sent out of the **Main Outputs**).

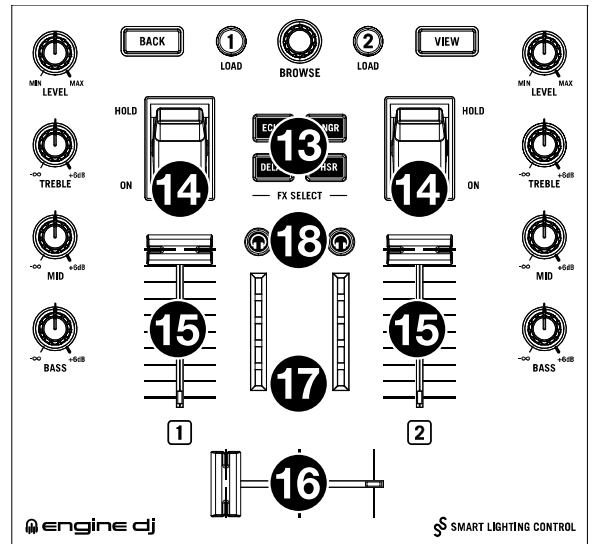

- 18. **Headphone Preview:** Press this button to preview the channel in the headphones. Use the **Headphone Mix** knob to adjust the mix between the channel’s pre-fader signal and the headphones’ cue channel.
- 19. **Headphone Mix:** Turn this knob to adjust the blend of the headphone cue and main channels together in the headphones.
- 20. **Headphone Volume:** Adjusts the volume for headphone cueing.
- 21. **Platter:** This capacitive, touch-sensitive platter controls the audio playhead when the wheel is touched and moved.
- 22. **Scratch Mode:** When this button is enabled, Smart Scratch mode will be active. In this mode, the track’s timeline continues (the lower half of the waveform in the display will continue moving forward) when you use the platter to "scratch" the track. When you release the platter, the track will resume normal playback from where it would have been if you had never moved the platter.

When Smart Scratch is enabled, press and hold **Shift** and press this button to enable jog mode. In this mode, touch the platter and move it to temporarily adjust the track’s speed.

Press this button again to disable Smart Scratch and enable vinyl mode for the platter. You can use the **platter** to “scratch” the track as you would with a vinyl record.

Note: Smart Scratch is enabled by default and can be adjusted in the [Settings](#) menu.

Press and hold the **Scratch Mode** button to enter or exit Grid Edit Mode. Use the controls on the touchscreen to edit the beatgrid. See [Beat Grid Editing](#) for more information.



- 23. **Sync / Sync Off:** Press this button to activate sync.

Press and hold **Shift** and press this button to deactivate Sync. You can also set Sync to deactivate without using Shift by changing the **Sync Button Action** setting in the **User Profile** menu.

- 24. **Cue / Previous:** When the Deck is paused, you can set a Temporary Cue Point by moving the **platter** to place the playhead at the desired location and then pressing the **Cue Button**.

During playback, you can press the **Cue Button** to return the track to this Temporary Cue Point. (If you did not set a Temporary Cue Point, then it will return to the beginning of the track.)

If the Deck is paused, you can press and hold the **Cue Button** to play the track from the Temporary Cue Point. Releasing the **Cue Button** will return the track to the Temporary Cue Point and pause it. To continue playback without returning to the Temporary Cue Point, press and hold the **Cue Button**, then press and hold the **Play Button**, and then release both buttons.

Press and hold **Shift** and then press this button to return to the beginning of the track.

- 25. **Play/Pause:** This button pauses or resumes playback.

Press and hold **Shift** and then press this button to “stutter-play” the track from the initial cue point.

- 26. **Pitch Fader:** Move this fader to adjust the speed (pitch) of the track.

Press and hold **Shift** and then press one of the **Pitch Bend** buttons to adjust the total range.

- 27. **Pitch Bend -/+:** Press and hold one of these buttons to momentarily reduce or increase (respectively) the speed of the track.

Press and hold **Shift** and then press one of these buttons to set the range of the **pitch fader**.

- 28. **Performance Pads:** These pads have different functions on each deck depending on the current pad mode. See **Pad Modes** for more information.

- 29. **Cue:** Press this button to enter **Cue** mode. Press the button again to enter a second bank of cues. To assign a cue to a pad, press a pad at the desired location in the track. To clear a cue from a pad, press **Shift** and the desired pad.

- 30. **Saved Loop:** Press this button to enter **Saved Loop** mode. Press the button again to enter a second bank of saved loops. To assign a loop to a pad and activate it, press a pad to create a Loop In point at the current location, and then press it again to create the Loop Out point at another location. To deactivate or reactivate a loop, press the corresponding pad. To delete a loop, press **Shift** and the desired pad.

- 31. **Auto Loop:** Press this button to enter **Auto Loop** mode. Press the button again to enter a second bank of auto loop lengths. To activate an auto loop, press a pad. To deactivate an auto loop, press the pad again.

- 32. **Roll:** Press this button to enter **Roll** Mode. Press the button again to enter a second bank of roll lengths. To trigger a roll, press a pad.

Press and hold **Shift** and then press this button to enter Sampler Mode.

- 33. **Speakers:** These speakers will play the same current audio as the Main Outputs. Use the **Speaker Level** knob to adjust the volume of the speakers.

- 34. **Main Level:** Turn this knob to adjust the volume level of the **Main Outputs**.

- 35. **Speaker Level:** Turn this knob to adjust the volume level of the **speakers**.



Front Panel

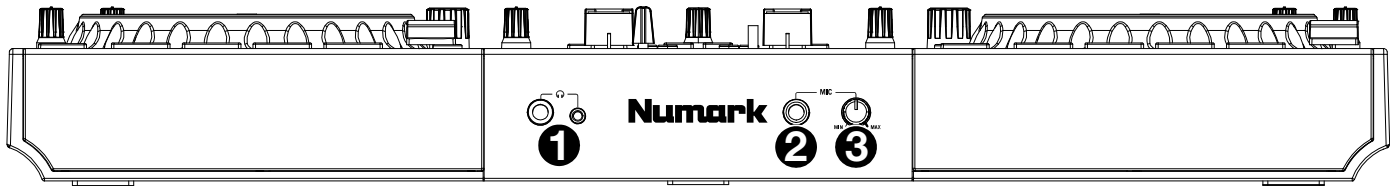

1. **Headphones (1/4", 1/8") (6.35 mm, 3.5 mm):** Connect your 1/4" or 1/8" (6.35 mm or 3.5 mm) headphones to this output for cueing and mix monitoring. The headphone volume is controlled using the **Cue Gain** knob.
2. **Mic Input (1/4" / 6.35 mm):** Use a standard 1/4" (6.35 mm) cable (not included) to connect a standard dynamic microphone to this input.
3. **Mic Level:** Turn this knob to adjust the volume level of the microphone input. You can adjust the microphone attenuation and routing in the **Settings** menu.

Rear Panel

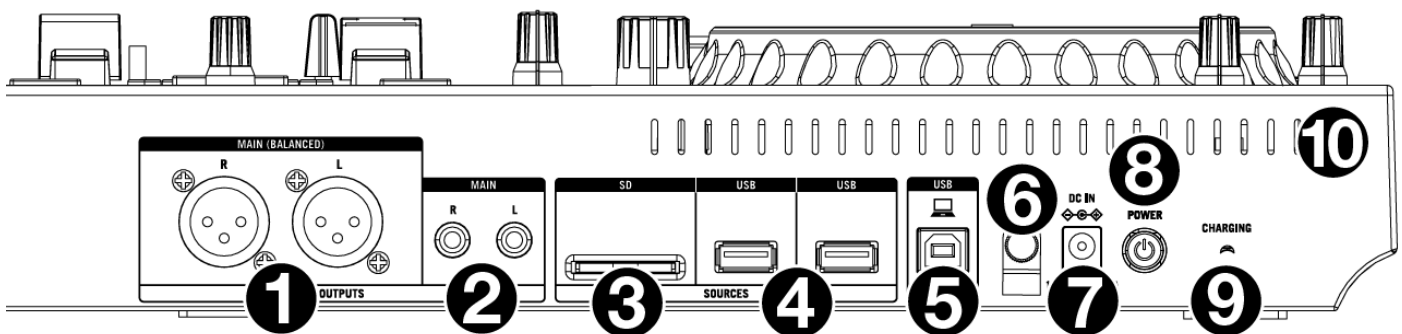

1. **Main Outputs (XLR, balanced):** Use standard XLR cables to connect these outputs to loudspeakers or an amplifier system. Use the **Main** knob on the top panel to control the volume level.
2. **Main Outputs (RCA, unbalanced):** Use standard RCA cables to connect these outputs to loudspeakers or an amplifier system. Use the **Main** knob on the top panel to control the volume level.
3. **SD Card Slot:** Insert a standard SD card to this slot. You can use the touchscreen to select and load tracks from your SD card.
4. **USB-A Ports:** Connect standard USB drives to these USB ports. When you select a USB drive as a source, you can use the touchscreen to select and load tracks from your USB drive. You can also connect a keyboard to these ports to easily search through your library.
5. **PC USB-B Port:** Use a standard USB cable (included) to connect this USB port to an available USB port on your computer.
6. **Power Adapter Restraint:** Secure the power adapter cable to this restraint to prevent it from accidentally unplugging.
7. **Power Input:** Use the included power adapter to power the unit.
8. **Power Button:** Press this button to power your Mixstream Pro hardware on. Power on your Mixstream Pro hardware only **after** you have connected all of your input devices and **before** you power on your amplifiers and loudspeakers.

To power off your Mixstream Pro hardware, press this button and follow the prompts on the touchscreen. Power off your amplifiers and loudspeakers **before** powering off your Mixstream Pro hardware.
9. **Charging LED (Mixstream Pro Go Only):** This LED will be lit solid red when Mixstream Pro Go is plugged in and charging. Once the battery has been fully charged, the LED will turn off.
10. **Vent:** Make sure this vent is unobstructed while using your Mixstream Pro hardware.

Operation

Touchscreen Overview

Performance View

Track Overview & Waveform

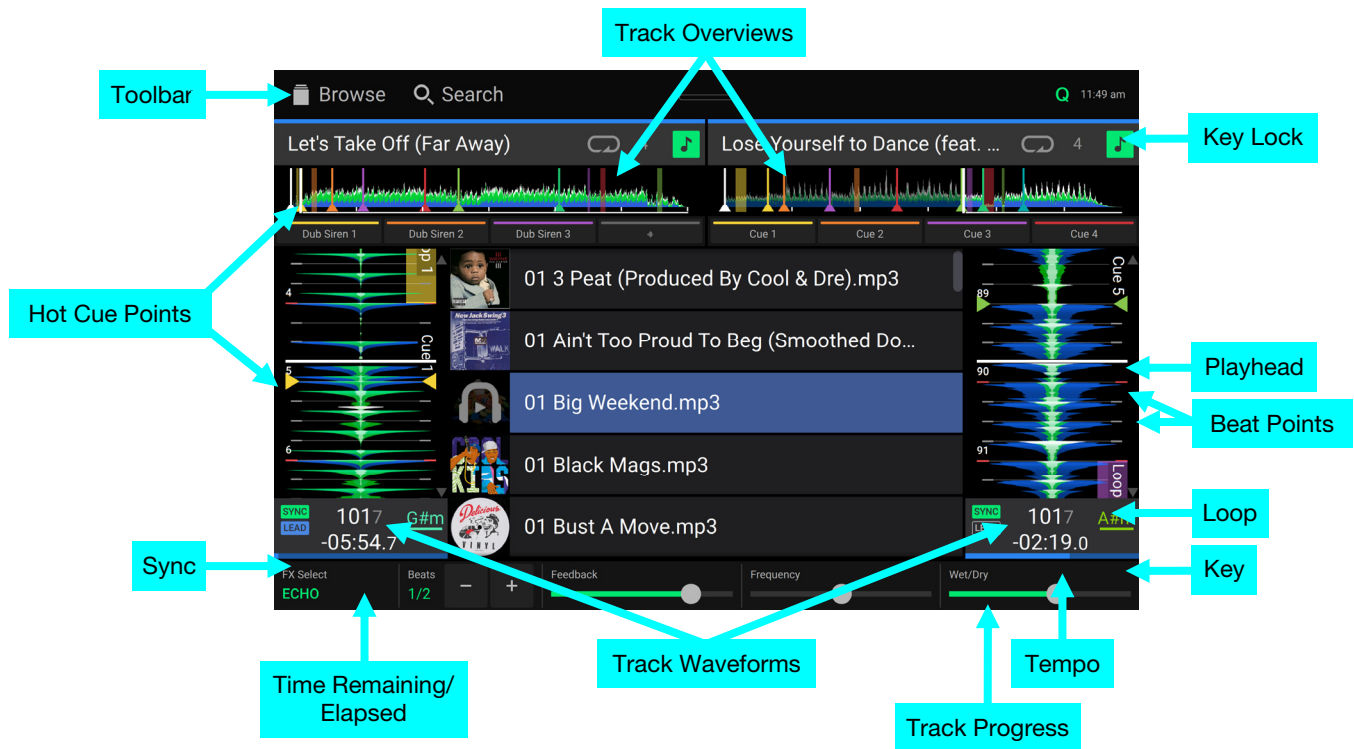

Swipe left or right on the track overview to scan through the track while the track is paused.

Note: You can use this feature during playback if Needle Lock is off. If Needle Lock is on, stopping the platter with your hand or palm will allow you to swipe through the track overview. See [User Profile](#) to learn about Needle Lock.

Spread or pinch your fingers on a waveform to zoom in or out of it, respectively.

Tap the time to switch between the elapsed time and remaining time.

Tap the key when Key Lock is on to change the key.

Hold Shift and press View to toggle between vertical and horizontal waveform views:

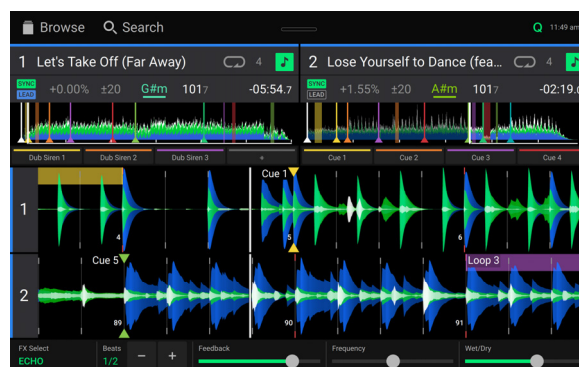

Horizontal Waveform View

Central Library Preview

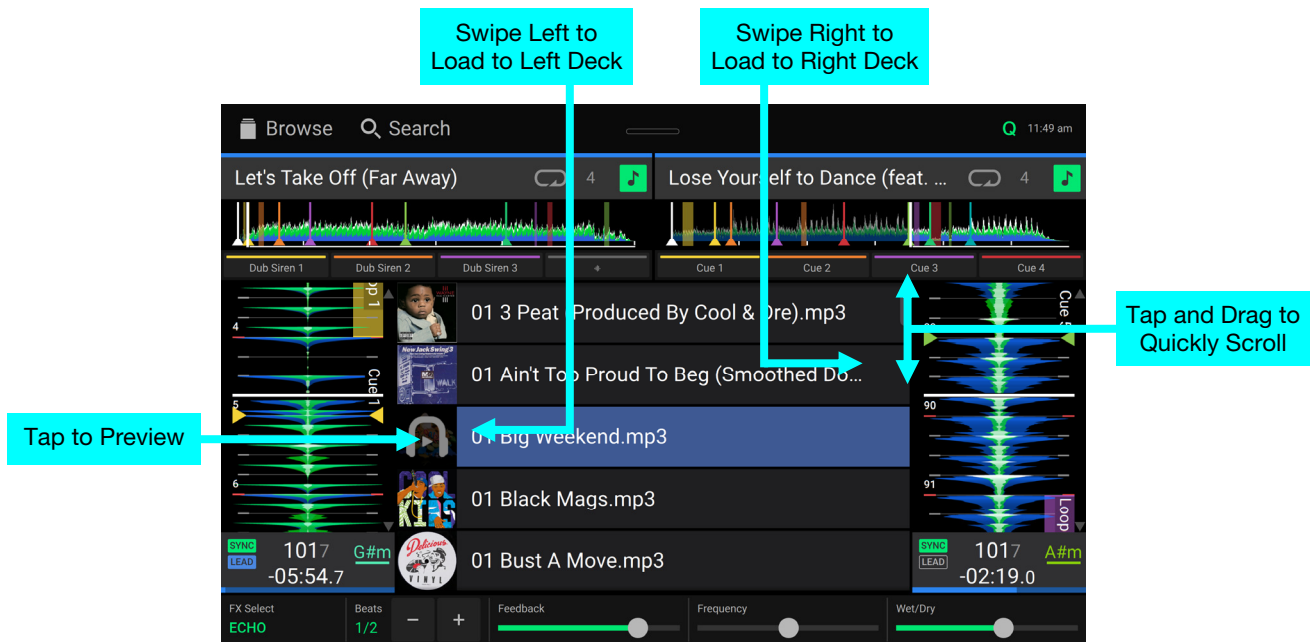

Swipe up or down to browse tracks.

Tap and drag the scroll bar to quickly browse through tracks.

Swipe right to load a track to the right deck.

Swipe left to load a track to the left deck.

Double-tap to load a track to a selected deck.

Tap the track art to preview the track. Tap again to stop previewing. While previewing, tap along the track entry to scan through the track.

Toolbar

The **toolbar** at the top of the touchscreen features shortcuts to [Library](#) view and displays the status of certain hardware and feature settings. **Swipe down** from this area to open the [Control Center](#).



Browse: Tap here to open the full [Library](#) screen.

Search: Tap here to search for tracks using the keyboard that appears in the display.

Q: Tap here to enable or disable quantization. When enabled, time-based features like triggering cues and loops will snap to the beat-grid according to the **Cue/Loop Quantization** setting in your [User Profile](#).

Continue: The figure-eight icon indicates Continue is enabled, which will keep playing the next track when the active track has ended.

Wi-Fi: Shows the current Wi-Fi connection status.

Battery: Shows the current battery life (Mixstream Pro Go only).

Link: Shows the current Ableton Link status. Enabling Ableton Link will synchronize the beat, phase, and tempo of Ableton Live and your EngineOS hardware over a wireless or wired network.

Time: Displays the current local time. You can adjust the Time in the [Settings](#) menu.

Library View

Use the full Library View to view your music library and load a track to the deck. You can also search through playlists, add tracks to the Prepare list, and search through your tracks using sorting and filtering features.

Important: Visit enginedj.com/downloads to download the Engine DJ software.

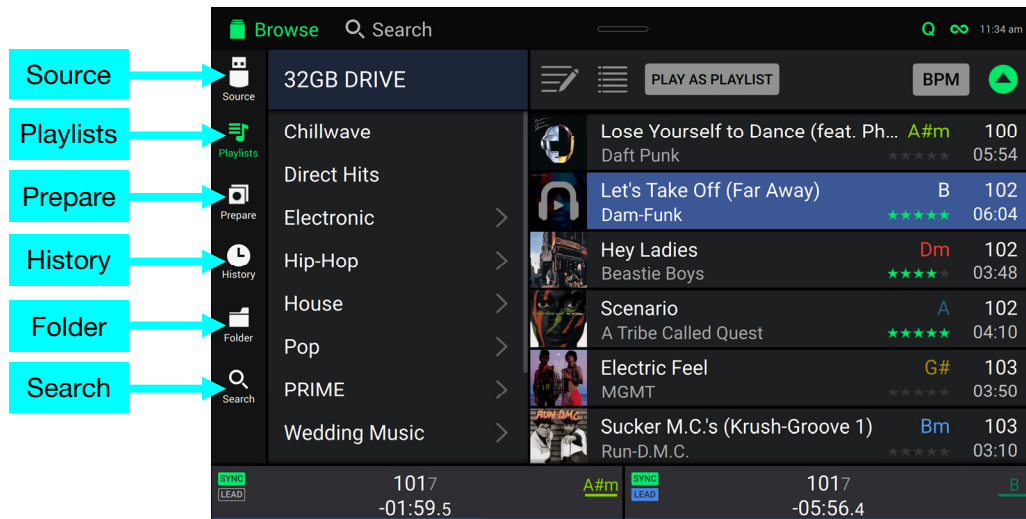

Use the six icons on the left side to navigate while in Library View:

- **Source:** Use this option to select the source device to view tracks from, including your connected media devices, available streaming and cloud services, Engine Remote Libraries, and pre-installed Demo and Sampler content. Tap the Source icon to show the list of available sources, and then tap to select. To enable streaming and cloud services, use the [Settings](#) menu.
- **Playlists:** Your playlists are your collections of tracks, including lists of tracks arranged in a specific order. You may have playlists for different types of clubs or events, for specific genres, etc. You can use the included Engine DJ software to create playlists to use here.
- **Prepare:** You can load tracks to the Prepare list so that you can refer to them later when you want to play them during your performance (rather than searching through your entire library for the next track to play).
- **History:** Use this option to view your playback history.
- **Folder:** Use this option to browse the list of all files on a USB drive or SD card.
- **Search:** Use this option to search through your tracks by keyword. See [Searching & Filtering Tracks](#) for more information.

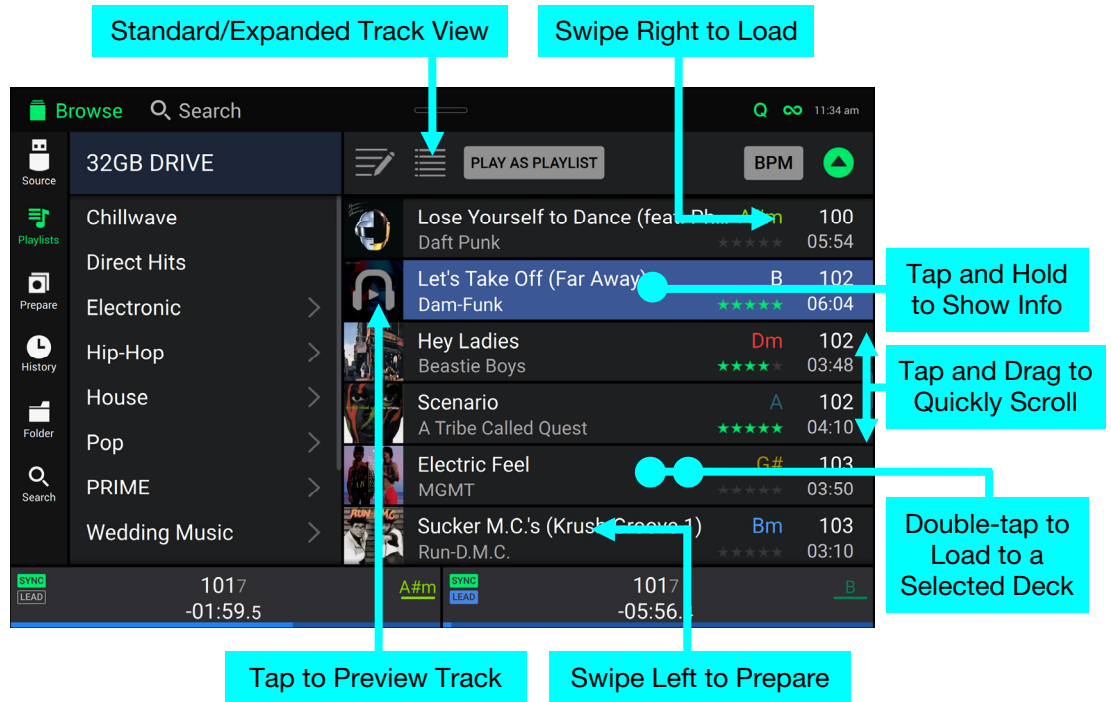

Tap the list icon at the top of the display to toggle between standard and expanded list views.

Swipe a list up or down to browse through it (e.g., your list of playlists or your list of tracks). Alternatively, press the **Back** or **Forward** buttons to select a list, and then turn the **Browse** knob.

Tap and drag the scroll bar to quickly browse through tracks.

Tap an icon or item in a list to select it (e.g., the icons for Playlists, Prepare List, Files, or Search on the left side of the Library). Alternatively, press the **Browse** knob.

Swipe a track to the right and tap **Load** to load it to a deck or sampler slot. Alternatively, press the **Browse** knob or double-tap the track. Tap the deck number, or turn and press the **Browse** knob, to select the desired deck.

Swipe a track to the left to add it to the Prepare list. Alternatively, press and hold **Shift** and press the **Browse** knob. Swipe a track to the left in the Prepare list to remove it.

Tap and hold your finger on a track to show its information window. Tap the information window to close it.

Tap the track art to preview the track. Tap again to stop the preview. While previewing, tap along the track entry to needle drop through the track.

Tap Play As Playlist to send the currently selected track list to a selected deck. See [Playlist Deck](#) to learn more.

Performing

Loading Tracks

To load a track to a deck, do any of the following:

- In the Central Library Preview, swipe the track to the left or right to load the track to the deck on that side.
- In Library View, swipe the track to the right, and then tap the desired Deck number.
- Highlight the track using the encoder, and then press the **Load 1/2** buttons to load the track to the deck on that side.
- Highlight the track using the encoder, then press the encoder to bring up the deck selection screen. Turn the encoder to select the desired deck, and then press the encoder to load the track to that deck.
- Double-tap the track to bring up the deck selection screen. Tap to select the desired deck.

To add a track to the Prepare list, swipe the track to the left while in **Library View**. Alternatively, press and hold **Shift** and press the **Browse** knob.

To show a track's information, tap and hold your finger on it.

While viewing the Prepare list:

Swipe left to remove the track from the Prepare list.

Tap the clear button in the upper-right corner of the touchscreen to remove all tracks from the Prepare list.

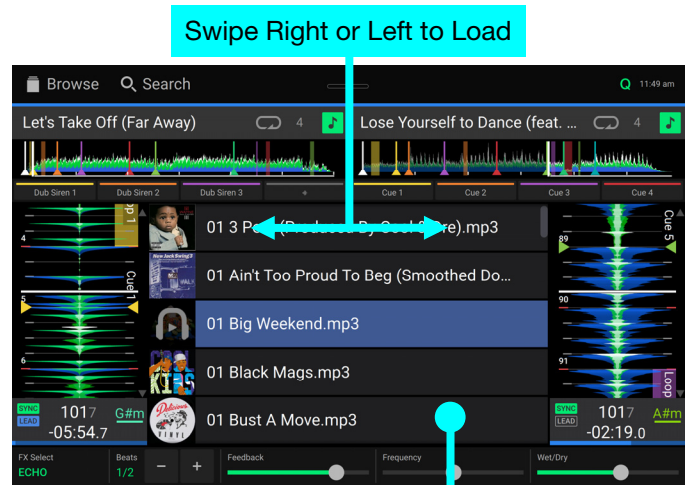

Tap and Hold to Show Info

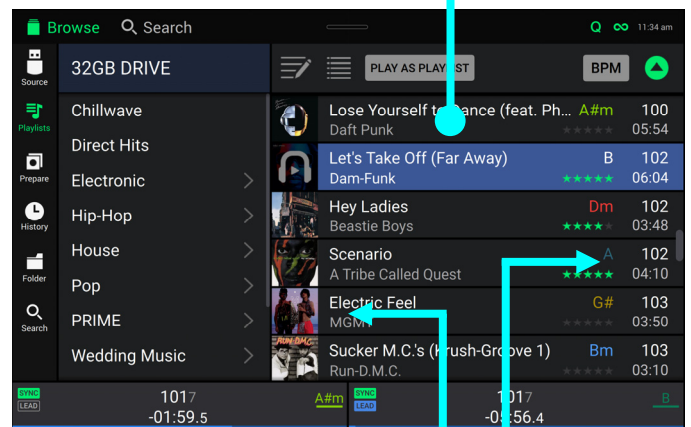

Swipe Left to Prepare

Swipe Right to Load

Searching & Filtering Tracks

To search, tap the **Search** field and use the keyboard that appears on the touchscreen. The search results can be based on the following criteria: title, artist, album, length, key, comment, BPM, genre, label, year, date added or filename. By default, only Title and Artist are selected. Use the dropdown menu next to the search bar to select other categories, or to Search All categories.

Note: To reduce search time, only select fields in which you wish to search.

To hide the keyboard, tap the **keyboard icon** in the lower-right corner of the virtual keyboard. Alternatively, tap anywhere on the screen other than the keyboard or the Search field.

To filter your tracks, tap **Genre, Artist, Album, BPM or Key**, and then tap one of the available options. Only tracks tagged with that genre, album, artist, BPM, or key will be shown. (By default, the key is notated using the Camelot system.) You can also use the **Search** field while tracks are filtered to refine your results.

Note: You can also use the User Profile to set whether you want to show tracks with the same key only or tracks with compatible keys as well as adjust the “tolerance” of the BPM filter (to include tracks with tempos within 1–15 BPM of the selection). See [User Profile](#) to learn more.

To sort the list of results, tap the **Sort By** icon in the upper-right corner, and then tap one of the available options. Tap the **arrow** icon next to this to toggle between ascending and descending order.

Tap to Select Search Criteria

Tap to Search

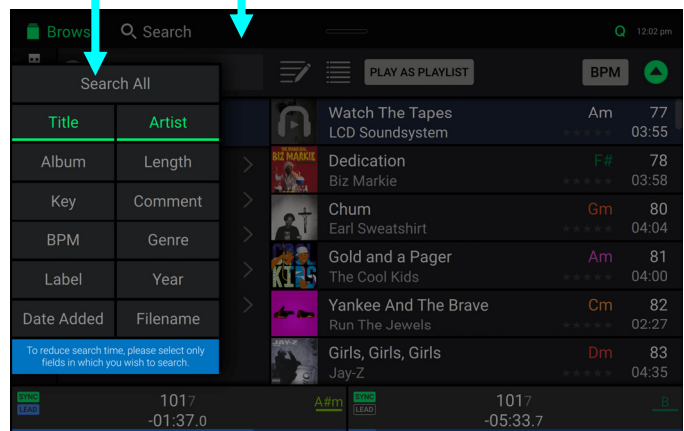

Tap to Filter Tracks

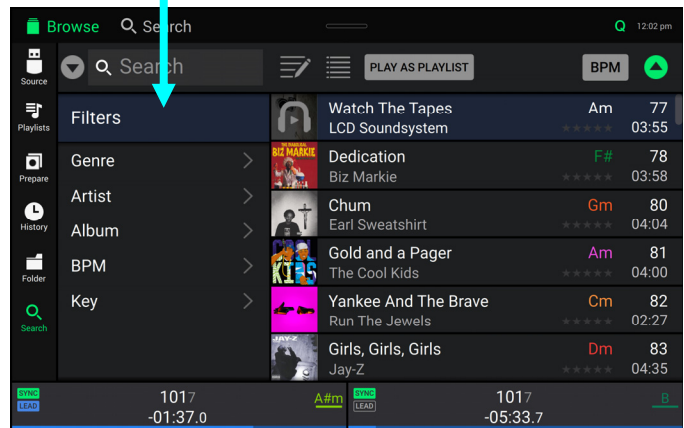

Tap to Toggle Ascending/Descending

Tap to Choose Sort Preference

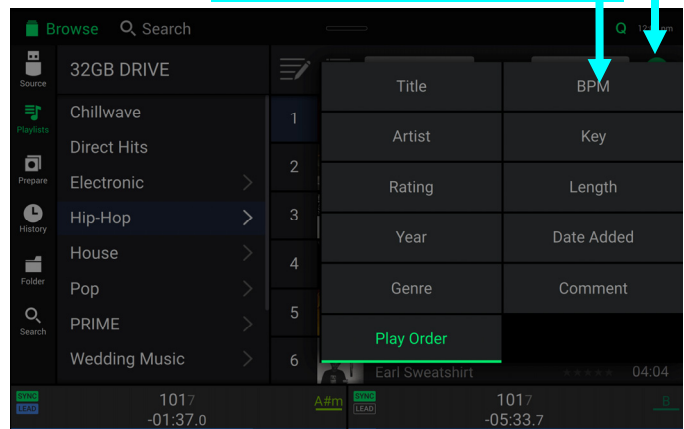

Editing Playlists

Tap the **edit button** at the top of the display while viewing the playlist screen. While editing is active, you can do any of the following:

To make a new playlist, tap **+ Create Playlist** in Playlist view.

To add tracks to your playlist, tap a track to select it, and the open circle will become filled. After selecting tracks, tap and hold to move the tracks. You can drag the tracks over a playlist or folder and release your finger to instantly add them.

To reorder tracks in a playlist, tap and hold on the track name (while editing mode is still active), then move your finger up or down to change the track order. You can also reorder playlists in the same way.

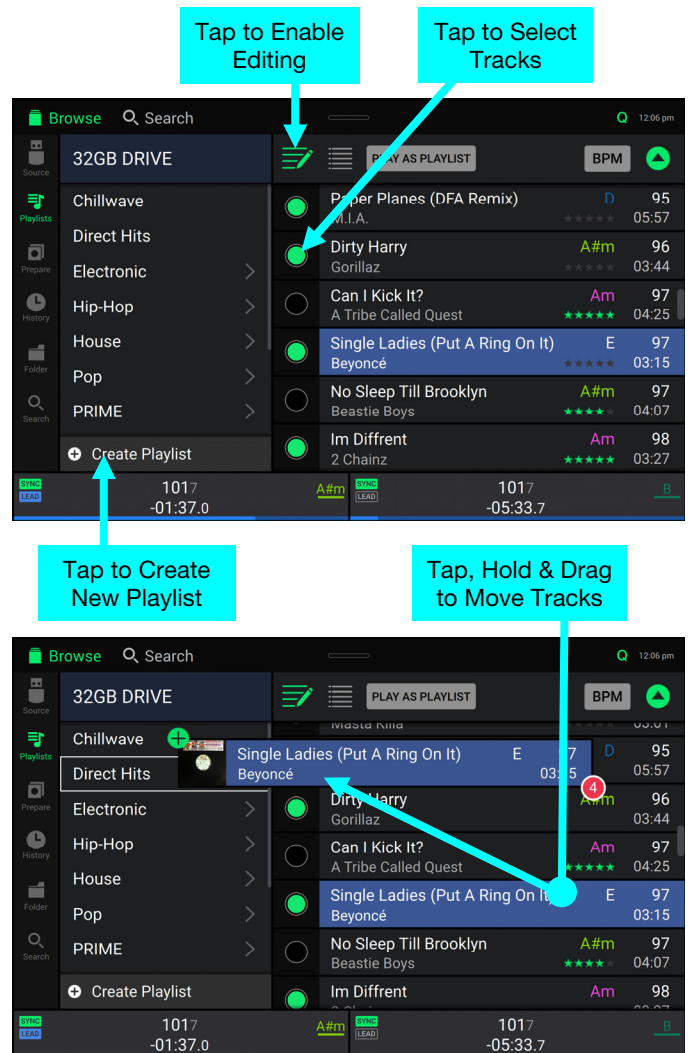

Playlist Deck

While in Library View, you can send the currently viewed file list to its own deck to play as a playlist.

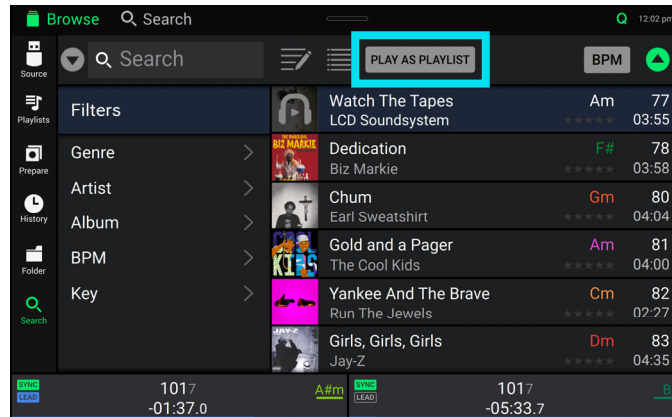

To enable **Playlist Deck**, tap **Play As Playlist** in Library view. When enabled, the playlist on deck will play through the selected track list and automatically crossfade between each track according to the **Playlist Deck Crossfade Time** parameter in the **Settings** menu.

Note: In Performance view, playlist decks are only available in vertical view.

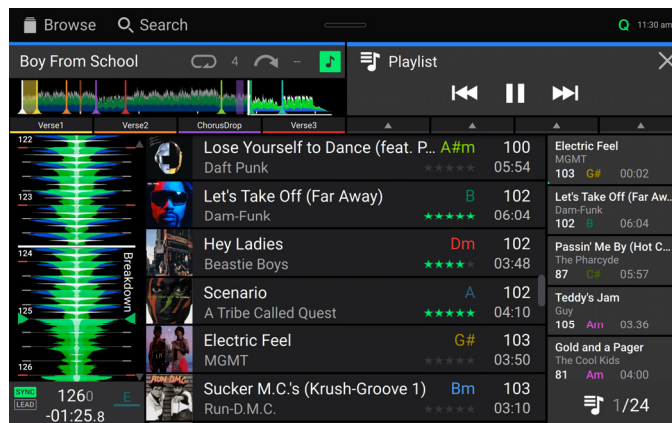

To enable **playlist deck playback**, press **Play** on the selected deck.

To change tracks within the playlist, use the **track backward** and **track forward** buttons in the track overview area.

To remove the playlist from the deck, tap the **X** in the track overview area.

Playback & Cueing

To play or pause a track, press **Play/Pause** (▶/||).

To **scratch a track**, move the **platter** when the **Scratch** button is set to **On** and audio is playing. Smart Scratch Mode is enabled by default, which the track's timeline continues (the lower half of the waveform in the display will continue moving forward) when you use the platter to scratch the track. When you release the platter, the track will resume normal playback from where it would have been if you had never moved the platter.

When Smart Scratch is enabled, press and hold **Shift** and press this button to enable jog mode. In this mode, touch the platter and move it to temporarily adjust the track's speed.

Press this button again to disable Smart Scratch and enable vinyl mode for the platter. You can use the **platter** to "scratch" the track as you would with a vinyl record.

To **set the initial cue point**, press **Cue** at the desired location while the track is paused.

To **return to the initial cue point and stop**, press **Cue** while the track is playing. The button will flash while the unit is paused at the initial cue point.

To **return to the initial cue point and "stutter" playback**, press and hold **Shift** and press **Play/Pause** (▶/||).

To **return to the beginning of a track**, press and hold **Shift** and press **Cue** in the middle of a paused track.

To **jump to a specific location in the track**:

- If Needle Lock is **disabled**: tap the desired location in the track overview.
- If Needle Lock is **enabled**: pause playback and then tap the desired location in the track overview. Alternatively, make sure the **platter** is in **Normal** scratch mode, touch the top of the platter and tap the desired location in the track overview.

See [User Profile](#) to learn about Needle Lock.

To **zoom in and out of the waveform**, place two fingers on the touchscreen and spread them apart or pinch them together.

Syncing & Pitch Adjustment

To **activate sync**, press **Sync** on the deck that you want to control the BPM, which becomes the "sync lead." After Sync is activated on that deck, press **Sync** on any additional decks. The tempo of each deck will immediately synchronize to match the tempo of the sync lead deck.

The Sync state icon in the display will indicate the current status:

 **Sync Off**

 **Sync On**

The Sync behavior is determined by the **Sync Mode** setting in the [User Profile](#) menu.

The Sync Lead icon in the display will indicate the current sync lead status:

 **Sync Lead**

 **Sync Follow**

To **deactivate sync on a deck**, press **Sync** again, or press and hold **Shift** and press **Sync**, depending on the setting of **Sync Button Action** in the [User Profile](#) menu.

To **adjust the track's pitch**, move the **pitch fader**.

To **adjust the track's pitch momentarily**, press and hold one of the **Pitch Bend** -/+ buttons.

To **adjust the range of the pitch fader**, press and hold **Shift** and press one of the **Pitch Bend** -/+ buttons to select $\pm 4\%$, 8% , 10% , 20% , 50% , or 100% .

To **lock or unlock the track's key**, press **Key Lock/Key Sync**. When Key Lock is activated, the track's key will remain the same even if you adjust its speed.

Beat Grid Editing

You can edit a track's beat grid directly from your Mixstream Pro hardware, the same way you can when using the Engine DJ software.

To enable beat grid editing, open the **Control Center** and tap the **Beat Grid Edit** icon. You can also open this menu directly by pressing and holding the **Scratch Mode** button.

Note: Beat grid editing is not accessible if there are no tracks added to the decks.

Important: When the **Cue/Loop Quantization** feature is **on**, hot cue points and loop points will be automatically aligned according to the degree of quantization. See [User Profile](#) to learn about this.



To adjust the position of the beats:

- Tap the **Downbeat Left/Right** buttons to move the beats based on the current analyzed grid.
- Tap the **Shift Left/Right** buttons or nudge the hardware platter to "slip" the entire grid left or right.
- Tap the **Insert Anchor** button to move the closest beat to the position of the playhead. All other beats will also shift accordingly. This allows you to create flexible beat grids for tracks with fluctuating tempo.
- Tap the **Delete Anchor** button to delete the closest anchor within a few beats.

To adjust the tempo:

- Tap the **BPM** field to input a new tempo. Use the number pad that appears to input the new value, and then tap the **Enter** button to accept it. Tap the **X** icon to cancel changes and return to the grid edit controls.
- Tap in the **Tap Tempo** icon area to manually set a tempo based on repeated taps.
- Tap the **Decrease/Increase BPM** buttons to decrease and increase BPM in small increments.
- Tap the **2X** and **/2** buttons to double or halve the current BPM.

To reset the beats to the original analyzed tempo and grid, tap the **Reset** button.

To lock the beat grid, tap the **lock** icon. When locked, further editing is prevented and all other Grid Edit controls will be greyed out.

To exit beat grid editing, tap the **X** in the top-right corner of the touchscreen, or select another mode.

Pad Modes

The 4 performance pads on each deck have different functions in each pad mode.

To enter each pad mode, press the corresponding button: **Cue**, **Saved Loop**, **Auto Loop**, or **Roll**.

To enter Sampler Mode, press and hold **Shift** and press **Roll**.

Cue Mode

In “hot” Cue Mode, you can use each pad to jump to an assigned hot cue point.

Tip: You can use the Engine DJ software to set, name, and assign colors to your hot cue points. The names and colors will appear on the touchscreen for reference.

To assign a hot cue to a pad, press a pad at the desired location in the track.

To jump to a hot cue point, press the corresponding pad.

To enter a second bank of hot cues, press the **Cue** button a second time.

To clear a hot cue from a pad, press **Shift** and the desired pad.

Saved Loop Mode

In Saved Loop Mode, you can use each pad to activate an assigned loop.

Tip: You can use the Engine DJ software to set and name your loops. The names will appear on the touchscreen for reference. You can also set active loops in the Engine DJ software, which will begin looping automatically as soon as they are reached, and are shown with a striped pattern in the track waveform.

To assign a loop to a pad and activate it, press a pad to create a Loop In point at the current location, and then press it again to create the Loop Out point at another location. The loop will activate immediately.

To deactivate or reactivate a loop, press the corresponding pad. Once a loop has been created, the loop will deactivate or retrigger depending on the **Saved Loop Behavior** setting in the [User Profile](#).

To enter a second bank of saved loops, press the **Saved Loop** button a second time.

To delete a loop, press **Shift** and the desired pad.

Auto Loop Mode

In Auto Loop Mode, you can use each pad to create and activate an auto loop.

To activate an auto loop, press a pad. The touchscreen will show the length of the auto loop for each pad.

To enter a second bank of auto loops, press the **Auto Loop** button a second time.

To deactivate an auto loop, press the pad again.

Roll Mode

In Roll Mode, you can press and hold each pad to trigger a “loop roll” of a certain length while the track’s timeline continues (the lower half of the waveform on the touchscreen will continue moving forward). When you release the pad, the track will resume normal playback from where it would have been if you had never done anything (i.e., as if the track had been playing forward the whole time).

To trigger a roll, press the corresponding pad.

To enter a second bank of roll lengths, press the **Roll** button a second time.

Sampler Mode

In addition to the Pad Modes above, Mixstream Pro hardware also includes a Sampler Mode. This can be accessed from your hardware by pressing and holding **Shift** and pressing **Roll**.

In Sampler Mode, you can assign and trigger up to eight samples using your performance pads. Press and hold **Shift** and press **Roll** again to access the second bank of sampler slots.

You can view your assigned samples in Performance View by enabling the Performance Pads widget in the **Control Center**. When the Sampler pad mode is selected, you will see the sample names loaded to each pad in the slots below the track overview waveform.

Your hardware includes a set of pre-installed sample content, which you can browse from **Library View** when **Sampler Content** is selected as a source. You can enable or disable this content from appearing using the **Sampler Content** setting under **User Profile**.

To load a sample from Library View, swipe the sample to the right, or double-tap the sample. Next, instead of selecting a deck, tap one of the eight sampler slots on the touchscreen. Alternatively, press the hardware pad where you want the sample assigned. If a sample is already loaded to the selected pad, the new sample will replace the existing sample.

Loaded samples will be retained in memory across device reboots and changes in Source drive selection.

To trigger a sample, press the performance pad on the hardware.

The sampler volume can be adjusted using the **Sampler Volume** slider in the **Control Center**. Sampler audio will be routed through the **Main Outputs**.

To stop a playing sample, hold **Shift** and press the performance pad.

To remove a sample, you must first exit Performance View. Samples cannot be removed while in Performance View to prevent accidental ejection. While in Library View, Settings, or another page, press and hold **Shift** and then press the performance pad with the sample you want to remove. If the sample is playing, you will need to stop it first, and then remove it.

Control Center

Press the **Control Center** button or **swipe down from the toolbar** to open the Control Center. Here, you can quickly adjust commonly used **Parameters** using the widgets in the center of the screen. You can also access the following pages. Click the links below to jump to that part of the guide:

- **User Profile** – This menu is used to edit your performance preferences.
- **Settings** – This menu is used to edit the settings of your Mixstream Pro hardware.
- **Source** – This menu is used for selecting your source media device.
- **Wi-Fi** – This menu is used for connecting to and configuring your Wi-Fi network.
- **Record** – This menu is used for recording and saving your performances.
- **Engine Lighting** – This menu is used for working with the SoundSwitch Engine Lighting integration.

Parameters

Quantize: Tap this to enable or disable quantization. When enabled, time-based features like triggering cues and loops will snap to the beat-grid according to the **Cue/Loop Quantization** setting in your **User Profile**.

Continue: Tap this to enable or disable continuous playback, which will keep playing the next track when the active track has ended.

Stop Time: Use this slider to adjust the stop time, or how long the track takes to stop playing after the pause button is pressed.

Beat Grid Edit: Tap this to access beat grid editing from the touchscreen. See **Beat Grid Editing** for more information.

Split Cue: Tap to enable or disable split cueing. When enabled, the headphone cue preview signal is summed to mono and sent to the left headphone channel and the main mix is summed to mono and sent to the right channel. When disabled, the cue channel and main mix will be “blended” together.

X Fader: Tap this to enable or disable the crossfader.

X Fader Contour: Use this slider to adjust the slope of the crossfader curve. Slide towards the left for a smooth fade (mixing) or slide to the right for a sharp cut (scratching). The center position is a typical setting for club performances.

FX Enabled: Tap this to display FX selection and parameters at the bottom of the touchscreen (see below).

Performance Pads: Tap this to enable or disable the performance pads from appearing in Performance View. When enabled, the pads will be shown under the track overview on the touchscreen (see below).

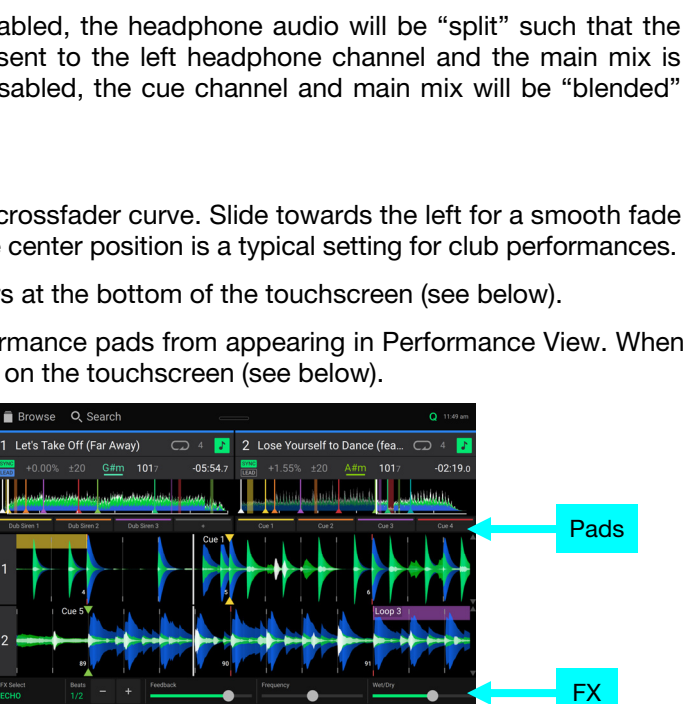
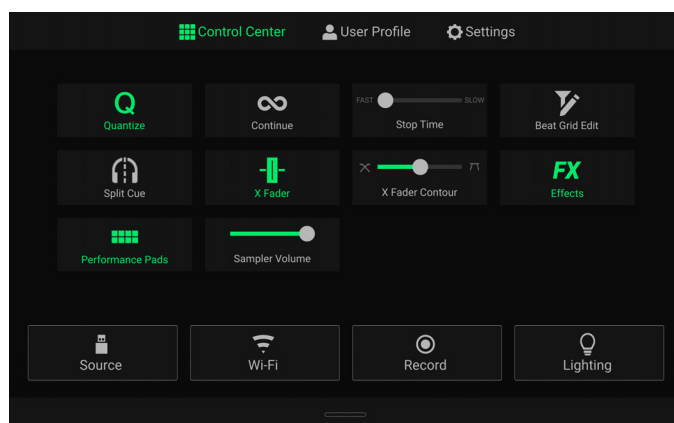

Sampler Volume: Use this slider to adjust the sampler volume level. See **Sampler Mode** for more information.

User Profile

Tap the **Save To My Drive** button to save your settings to a connected drive. User profiles can be loaded when a media device with an Engine DJ profile is connected to your Mixstream Pro hardware.

Playback

- **Track Start Position:** This setting determines where the beginning of a track is after it loads. Select the actual start of the file (**Track Start**) or the automatically detected beginning of an audio signal (**Cue Position**).
- **Default Speed Range:** This setting determines the range of the **pitch fader**. Select **±4%**, **8%**, **10%**, **20%** or **50%**.
- **Nudge Sensitivity:** This determines the level of sensitivity when moving the platters: **Min**, **Low**, **Mid**, **High**, or **Max**.
- **Sync Mode:** This setting determines the degree of synchronization applied when you press the Sync button on your Mixstream Pro hardware:
 - **Bar:** The tempo will be synced, and the track will be automatically bar-matched with the track on the sync lead deck (the downbeats of each bar will be aligned).
 - **Beat:** The tempo will be synced, and the track will automatically beat-matched with the track on the sync lead deck.
 - **Tempo:** Only the tempo will be synced (the BPM will match that of the sync lead deck).
- **Sync Button Action:** This setting determines how the **Sync** button will act when pressed.
 - **Toggle:** This mode allows you to toggle sync on and off without having to hold **Shift**.
 - **Shift Disable:** This mode requires **Shift** to be held in order to turn off sync.
- **Always show Sync Lead Button:** This setting determines whether the **Sync Lead** button appears over the main waveforms in Performance View. You can tap this button to set the deck as the sync lead.
- **Pitch Control Type:** This setting determines the primary function of the Pitch Bend buttons. Select **Pitch Bend** to keep the primary function as momentarily reducing or increasing the pitch, or select **Range** to set the primary function to adjusting the range of the pitch fader. The function not used as the primary will still be available by holding **Shift** and using the **Pitch Bend** buttons.

Cues/Loops

- **Cue/Loop Quantization:** This setting determines the degree of quantization for time-based features. Select **1/8** beat, **1/4** beat, **1/2** beat, **1** beat or **4** beats.
- **Paused Hot Cue Behavior:** This setting determines how pads will play their hot cue points. When set to **Momentary**, playback will start from a hot cue point when you press and hold its pad—release the pad to return to the hot cue point. When set to **Trigger**, playback will start from a hot cue point (and continue) when you press and release its pad.
- **Smart Loops:** This setting determines whether or not a manual loop will be automatically expanded or reduced to a conventional length (e.g., 2 beats, 4 beats, 8 beats, etc.) when you set it. Select **On** or **Off**. This setting works independently of the quantization setting.
- **Move Cue To Loop In:** This setting determines whether the song's initial **Cue Point** will automatically be moved to the start of a loop (**On**), or remain at its current point (**Off**).

Display

- **Track Title:** This setting determines whether track titles are shown as the track's **Filename** or its embedded **Metadata** (tags).
- **Time Format:** This setting determines whether or not pitch adjustment affects how the track time is displayed. When set to **Static**, the track's time corresponds to locations in the track as usual; adjusting the pitch does not affect it. When set to **Dynamic**, the track's time will automatically adjust to account for changes in pitch. For instance, if you set the pitch fader to **-8%**, the track time will increase so it is 8% longer.
- **Track End Warning:** This setting determines how long before the end of a track that your Mixstream Pro hardware will warn you that it is nearing the end by flashing the track overview on the touchscreen.

Safety

- **Lock Playing Deck:** This setting determines whether or not you will be able to load a track to the deck as it is playing. Select **On** or **Off**. When this setting is on, the deck must be paused in order to load a track to it.
- **Needle Lock:** This setting determines whether or not you can tap the **track overview** on the touchscreen to jump to that location in the track during playback. Select **On** or **Off**. You can use the track overview while playback is stopped regardless of this setting.
- **Pad Lock:** This setting determines whether the pads and pad mode buttons are always enabled (**Off**) or disabled (**On**). When disabled, the pads and pad mode buttons will not be lit.

Library

- **Key Notation:** This setting determines how the track key is notated on the touchscreen. You can view the key as all **Sharps**, all **Flats**, **Open Key** or **Camelot**.
- **Key Filter:** This setting determines whether the **Key** filter shows tracks with the same key only (**Match**) or tracks with compatible keys (**Compatible**).
- **BPM Range:** This setting determines the lowest- and highest-possible BPM values that will be used when tracks are analyzed: **58–115**, **68–135**, **78–155**, **88–175** or **98–195 BPM**.
- **BPM Filter Tolerance:** This setting determines the “tolerance” of the **BPM** filter so you can include tracks with tempos that are within a small range of the selected tempo. Select **±0**, **1**, **2**, **3**, **5**, **10**, or **15**.
- **Collection Browse Behavior:** This setting determines browsing behavior when using the Library. When set to **Select**, tapping a playlist or folder will select it, and a double-tap is required to open it. When set to **Open**, tapping a playlist or folder will open it.
- **Demo Content:** Use this option to enable or disable the pre-installed demo content.
- **Sampler Content:** Use this option or enable or disable the pre-installed sampler content.

Deck Colors

To change the deck color, tap the color box under the name of the deck, and then tap the color to select.

Settings

Device

- **Wi-Fi:** This determines whether Wi-Fi connectivity is enabled (**On**) or disabled (**Off**). Tap the **gear icon** to open the Wi-Fi settings. See [Wi-Fi](#) for more information about the Wi-Fi menu.
- **Time/Date:** This displays the current local time and date. Tap **Sync Time** when connected to the internet to automatically sync the time.
- **Time Zone:** Displays the current time zone, formatted as **Continent / City**.
- **Set time zone manually:** Enable this setting and then tap the **gear icon** to manually set your local time zone.
- **Default Scratch Mode:** This determines the default platter scratch behavior. Select **Normal** to default the platters to vinyl mode, allowing you to “scratch” normally as you would with a vinyl record. Select **Smart** to default the platters to **Smart Scratch** mode, where the track will continue playing as you scratch the platters and resume normal playback from where it would have been if you had never moved the platter.
- **Track Preview:** When active, Track Preview will reveal a play button for each song in the library, allowing the songs to be auditioned in the cue without loading a song to the deck. Select **On** or **Off**.
- **Preview Volume:** Use this slider to set the volume level of the track preview.
- **Screen Brightness:** This setting determines the brightness of the touchscreen: **Low, Mid, High, or Max**.
- **Screen (Battery)** (Mixstream Pro Go only): This setting determines the brightness of the main display when running on battery power: **Low, Mid, High, or Max**.

Mixer

- **Playlist Deck Crossfade Time:** Use this slider to adjust the amount of crossfade between tracks when using the playlist deck.
- **VU Meter Mode:** This setting determines which signal is represented by your Mixstream Pro hardware’s **Main Level Meters**. Select **Main** to use view the Main output level, or select **Channel** to use the Channel level.
- **Filter Resonance:** This setting determines the amount of resonance of the filter, from **0** to **15**.
- **Sum Main Out To Mono:** This setting enables or disables summing the audio to the **Main Outputs** to a mono signal (**On**). When disabled (**Off**), the audio will be sent in stereo.
Note: This setting does not apply to audio played through the built-in speakers.
- **Reset Effects Upon Load:** When enabled, each time an effect is loaded it will be loaded with all its settings at their default values. When disabled, effects settings will be retained the next time the effect is loaded.
- **Reset Effects to Default Settings:** Tap here to manually reset effects to the default settings.

Mic

- **Send to Speakers:** This setting determines whether the microphone signal is sent to the onboard speakers (**On**) or not (**Off**).
- **Send to Headphones:** This setting determines whether the microphone signal is sent to the headphone outputs (**On**) or not (**Off**).
- **Mic EQ:** These settings allow you to adjust the **Treble, Mid, and Bass** equalization for the microphone signal, from **-15.0** to **6.0 dB**.

Services

- **Sync:** This determines whether Ableton Link is enabled (**On**) or disabled (**Off**). Ableton Link synchronizes beat, phase, and tempo of Ableton Live and Ableton Link-enabled applications over a wireless or wired network. You must be connected to the internet to use Ableton Link.
- **Streaming:** Use these options to enable or disable connections to streaming service partners. When set to **On**, the selected service will be available in the **Source** menu.
- **Cloud:** Use this option to retrieve your Engine library database from a cloud storage service. You must first use the Engine DJ software to back up your database. Then, when this option is set to **On**, the selected service will be available in the **Source** menu and you can access these files over an established internet connection.

Note: We recommend using only high-quality, name brand USB 3.0 or Class U1 or U3 SD cards as source drives, especially when cloud services are enabled.

About / Update

This page displays the product name, current firmware version, and other device information.

- **Update Firmware Version:** If you are not running the latest firmware, tap **Reboot** to restart Mixstream Pro in Update Mode, which enables you to update its firmware. Follow the firmware update instructions included with the firmware update package you downloaded.
- **Send Anonymous Usage Statistics:** This determines whether or not your usage statistics will be sent occasionally to us, enabling us to improve the Mixstream Pro hardware experience.
- **Factory Reset:** Tap here to restore the default factory settings for your device.
- **Legal:** Tap here to view the Numark EULA and patent list.

Source

The Source menu allows you to select a connected media device, streaming service or cloud service for use with your Mixstream Pro hardware. All connected media sources will be shown in the top part of the display, and available streaming and cloud service partners at the bottom of the display.

To select a drive as a media source, tap the device name. The currently selected source device, if any, will show **Source** next to its name. The currently selected recording device, if any, will show **Rec** next to its name.

To select a streaming or cloud service as your source, tap the streaming or cloud service name. If you have not set up a connection to the service yet, you will be prompted to sign in with your username and password or given a web link and code in order to activate your device. Once signed in or activated, you can use the streaming or cloud service to browse and add tracks. Streaming and cloud services may be enabled or disabled in the [Settings](#) menu.

To open [Wi-Fi](#) connection menu, tap the **Wi-Fi** icon at the top of the display.

To switch your Mixstream Pro hardware to computer mode, tap the computer icon at the top of the display. In computer mode, you can use your Mixstream Pro hardware to send and receive MIDI messages to and from your computer.

To eject a drive source, tap the eject icon next to the drive name. If a track from the selected source is currently in use, an alert will appear to note that the tracks will be unloaded. Tap **Eject Anyway** to continue or tap **Cancel** to return to the Source menu.

To exit the Source menu, tap the **X** at the top-right of the display.

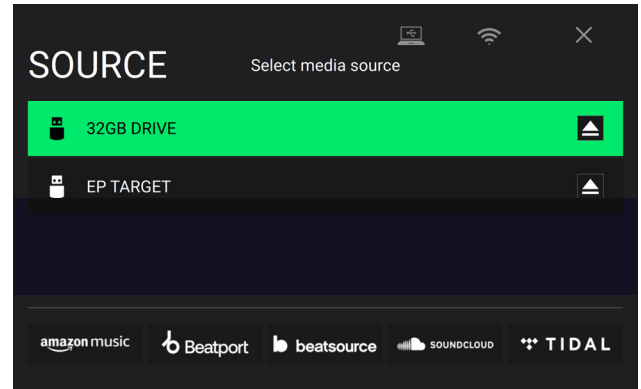

Note: Amazon Music is available with Mixstream Pro + only.

Engine Remote Library

In addition to connected devices, streaming services, and cloud services, you can also connect to an instance of the Engine DJ software running on a computer sharing the same network as your Mixstream Pro hardware. This allows you to browse and load tracks from your complete library without having to pack files to a portable drive.

To access your Engine Remote Library:

1. First, make sure your hardware and your computer are on the same network, and the Engine DJ software is opened. This can be done by connecting to the same Wi-Fi network, or by connecting directly using an Ethernet cable.
2. Tap the **Source** icon in Library View from your hardware, and locate your computer under the **Engine DJ Desktop** section.
3. Tap to select the computer, and your hardware will show “Waiting for confirmation” while another message appears in the Engine DJ software asking to accept or deny access to your hardware. Click **Accept** to approve and continue.

If the connection process is canceled, or if the connection is lost, both libraries will return to their previous selections.

4. Once the connection is established, you will be able to browse and load tracks from your Engine DJ software collection directly from your hardware.
5. When you load a track from the Engine Remote Library, the track will begin downloading over the network. The download progress will be shown on your hardware touchscreen. If the download fails, a “Failed to Download” message will appear on your hardware. You can remotely load tracks up to 250 mb in size.

Tracks will download with any performance data associated with the file in your Engine DJ software collection. This includes beat grids, saved cues, and saved loops. If no beat grid information is included with the downloaded track, your Mixstream Pro hardware will analyze the file once it is loaded.

Any edits made to performance data, track metadata, and playlists from your Mixstream Pro hardware or Engine DJ software will automatically sync to the other.

Wi-Fi

The Wi-Fi menu allows you to connect to a local internet network so you can browse connected streaming and cloud services.

To enable Wi-Fi, tap the **Wi-Fi icon** at the top of the page. Once enabled, a list of local networks will appear on the display.

To establish a connection, tap the desired network name. If a password is required, you will be prompted to enter it. Once a connection is established, **Connected** will appear next to the network name.

To view information about the network, tap the **gear icon** next to the network name:

Tap the Auto Connect On/Off buttons to enable or disable automatic connection to the network

Tap Forget to forget the network login credentials.

Tap Close or anywhere outside the menu to close the Wi-Fi information menu.

You can also disable Wi-Fi from within this menu by tapping the icon at the top of the display again.

Record

Select the media device destination that you will use to save your recording. The currently selected source device will show **Source** next to its name. Once you have selected the recording device, you can begin recording your session.

To begin recording, tap **Start**. The timer on the touchscreen will show the total length of time recorded.

To pause recording, tap **Pause**.

To resume recording when paused, tap **Resume**. Your Mixstream Pro hardware will continue recording your session from where you pressed pause.

To stop recording, tap **Stop**. Once recording is stopped, you will have the option of saving the file to your device.

To clear the recording, tap **Clear**. A warning screen will be shown before the file is deleted. Tap **Yes** to continue, or **No** to return to the previous page to save the recording.

To save the recording to your drive, tap **Save As**. A keyboard will appear where you can title your file. Tap **Done** to finish and save your file, or tap **Cancel** to return to the previous page. A success message will be shown on the display when the operation is complete. Tap **OK** to continue, or wait a few seconds and you will be returned to the Record menu.

Recorded files will be saved in a folder called **Sessions** on your media device. You can access these recordings from your Mixstream Pro hardware under the **Files** section of the **Library**.

To move back a page or return to the previous page, tap the **back arrow (<)**.

To exit the Record menu, tap the **X**.

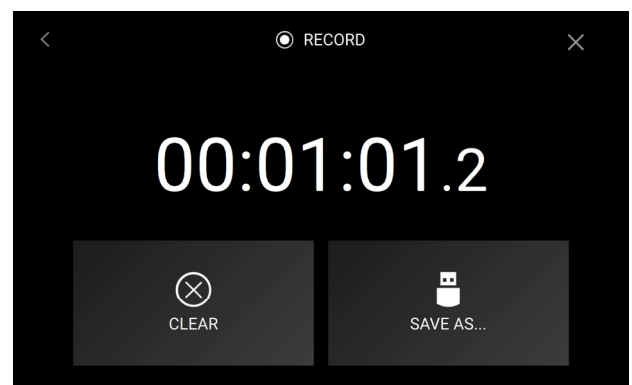
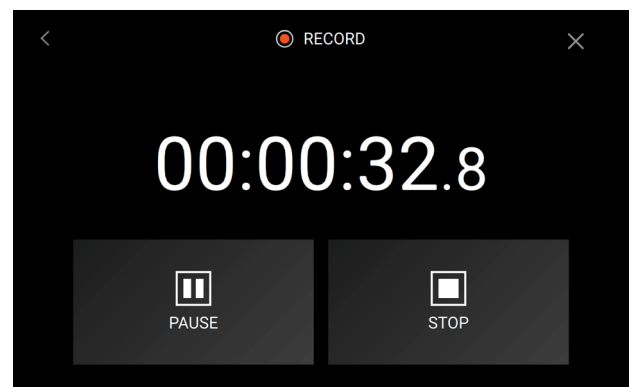
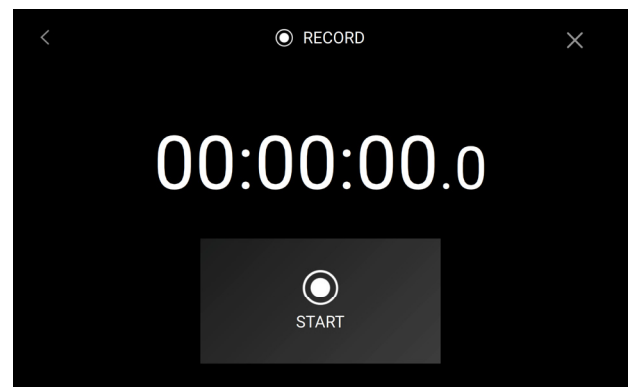
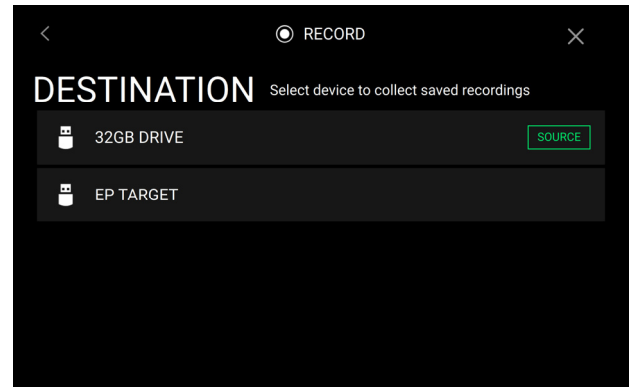

Engine Lighting

The Engine Lighting menu allows you to control connected lighting devices such as DMX fixtures and Smart Lights using SoundSwitch to seamlessly sync your music and lights.

To open Engine Lighting control, press the **Lighting** button. You can also tap the **Lighting** button in the **Control Center**.

The first time you use Engine Lighting, you can select a **Basic** or **Pro** layout for performing:

Basic: A simple interface for controlling Smart Lights, Control Color, Blackout and Strobe Lighting FX.

Pro: Full control of all lighting effects for both DMX and Smart Lights, Control Movements, Strobe and more.

You will also be prompted if you want to connect Philips Hue or Nanoleaf Smart Lights when you first use Engine Lighting. This can also be configured later through the Engine Lighting **Preferences** menu.

Visit soundswitch.com for more information on using SoundSwitch lighting controls with your hardware.

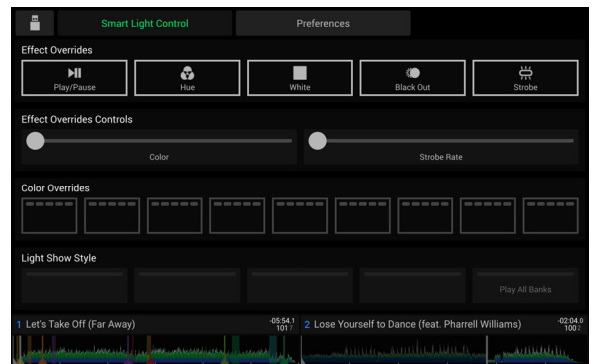

Basic View

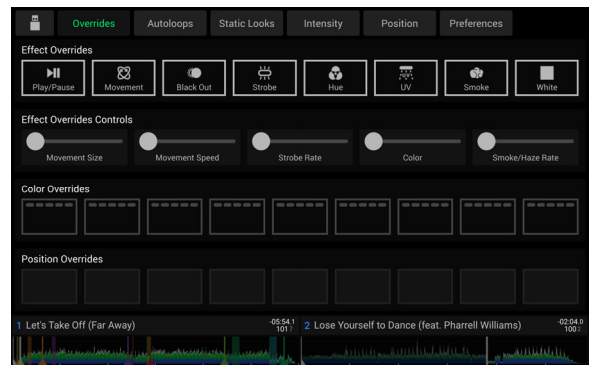

Pro View

Preferences

Tap the **Preferences** tab at the top of the touchscreen to open the Engine Lighting settings.

General

- **Engine Lighting Status:** This setting displays the current connection status to Engine Lighting devices. When **Running** is shown, Engine Lighting is active. Tap **Stop** to deactivate Engine Lighting. Tap **Start** to reactivate.
- **Connection Status:** These indicators will show whether Engine Lighting is receiving signal from up to four connected players.
- **Sync Offset:** Use this slider to apply a time offset for syncing your connected lights, from **-1** to **0** to **+1** seconds.
- **Show Advanced Controls:** Enable this option to toggle between the **Basic** and **Pro** controls.
- **Randomize Autoloops:** This setting determines whether autoloops are randomized or play in order.
- **Override Scripted Tracks:** This setting determines whether a scripted track that is paired with an audio file is used (**Off**) or whether you can override it using the onboard controls (**On**).
- **Loop Auto Strobe:** This setting allows you to automatically generate strobe effects when a Loop Roll is engaged.
- **Broadcast Art-Net:** This setting allows you to enable or disable sending Art-Net protocol to control DMX interfaces over a network connection.
- **Strobes:** This setting determines whether strobe effects are enabled or disabled.
- **Philips Hue:** Enable this option to connect to available Philips Hue smart devices.
- **Nanoleaf:** Enable this option to connect to available Nanoleaf devices.
- **Fader Mode:** This setting determines whether the light show changes continuously when both the crossfader and channel faders are moved (**Blend**) or only by the position of the channel faders (**Upfader Only**).
- **Active Faders:** This setting allows you to enable or disable Engine Lighting control on up to four channels at a time. Tap the **CH1-CH4** names to activate each channel.
- **Version:** Displays the current Engine Lighting version.

DMX Interfaces

Use this screen to view connected DMX interfaces and their Universe Assignments.

Philips Hue

Use this screen to set up Philips Hue devices.

Nanoleaf

Use this screen to set up Nanoleaf devices.

Appendix

FX Parameters

Echo	Parameter	Value Range
This effect adds echoes of the original signal.	Beats	1/32, 1/16, 1/8, 1/4, 1/3, 1/2, 3/4, 1, 3/2, 2, 3, 4
	Feedback	0–100

Flanger	Parameter	Value Range
This effect adds a slightly delayed copy of the original signal to create a comb-filter effect (often referred to as resembling a jet plane engine).	Beats	1/16, 1/8, 1/4, 1/2, 3/4, 1, 2, 4, 8, 16, 32
	Mix	0–100

Delay	Parameter	Value Range
This effect adds repeated instances of the original signal that decay over time.	Beats	1/32, 1/16, 1/8, 1/4, 1/2, 3/4, 1, 2, 4
	Feedback	0–100

Phaser	Parameter	Value Range
This effect adds a copy of the original signal with its phase shifted slightly to create a subtle, modulatory effect.	Beats	1/16, 1/8, 1/4, 1/2, 1, 2, 4, 8, 16, 32, 64
	Mix	0–100

Technical Specifications

Main Outputs		
Frequency Response	20 Hz – 20 kHz +/- 1 dB	
Dynamic Range	> 114 dB (A-weighted)	
Signal-to-Noise Ratio	> 94 dB (A-weighted)	
Headroom	Mic	> 16 dB
	Outputs	> 16 dB
Channel Separation	< -110 dB (1 kHz, unity)	
T.H.D.	Line	< 0.01% (1 kHz, unity)
	Microphone	< 0.05% (1 kHz, unity)

Speakers	
Frequency Response	20 Hz – 20 kHz +/- 1 dB

General		
Analog Input	Microphone	-40 dBu (unity) -60 dBu (minimum)
	Analog Output	<p>Main, Balanced +20 dBu (maximum) +4 dBu (unity)</p> <p>Main, Unbalanced +16 dBu (maximum) 0 dBu (unity)</p> <p>Headphone Output < 30 mW</p>
Playable Media	Type	SD, SDHC, SDXC card USB mass-storage devices (flash memory, external HDD enclosures)
	File Systems	exFAT (recommended) FAT32
	File Formats	AAC/M4A AIF/AIFF (44.1–192 kHz, 16–32-bit) ALAC FLAC MP3 (32–320 kbps) MP4 Ogg Vorbis WAV (44.1–192 kHz, 16–32-bit)

Connections	Audio Outputs	2 XLR outputs (main left/right, balanced) 1 RCA output pair (main left/right, unbalanced) 1 1/4" (6.35 mm) stereo output (headphones) 1 1/8" (3.5 mm) stereo output (headphones)
	Audio Inputs Other	1 1/4" (6.35 mm) microphone input 2 USB port (for USB drives) 1 USB port (to computer) 1 SD card slot 1 power adapter input
Display	Full color LED-backlit display with touch interface 7" / 178 mm (diagonal)	
Wi-Fi	Frequency	2.4 GHz / 5 GHz
	Standard	802.11a/b/g/n/ac
Bluetooth Version	5.0	
Power	Connection: DC, Center Positive Voltage: 12.0 V 3.0 A	
Dimensions <small>(width x depth x height)</small>	22.3" x 11.2" x 2.9" 566 x 284 x 74 mm	
Weight	8.11 lbs. / 3.68 kg	

Specifications are subject to change without notice.

Trademarks & Licenses

Numark is a trademark of inMusic Brands, Inc., registered in the U.S. and other countries.

Engine DJ incorporates élastique Pro V3 and [tONaRT] V2 by zplane.development.

macOS is a trademark of Apple Inc., registered in the U.S. and other countries.

SD, SDHC and SDXC are registered trademarks of SD-3C, LLC.

Windows is a registered trademark of Microsoft Corporation in the United States and other countries.

All other product names, company names, trademarks, or trade names are those of their respective owners.

This product uses software and technology under license. Please visit enginedj.com/product-legal for a complete list.

numark.com
